

Applications:



Data Centers



Telecommunication Networks



Industrial Automation



CAT6A



High-Speed



EMI Prevention

Discover Hirose's newest addition – the TM61P Series.

Meet Hirose Electric's TM61P Series: Your gateway to superior network performance. This RJ45 modular plug supports Cat.6A standards, ensuring 10Gbps transmission at 500MHz. Designed for easy assembly and effective EMI prevention, the TM61P Series is perfect for data centers and industrial applications, providing reliable and high-speed connections where it counts.

HIGHLIGHTS:

Key benefits of the TM61P Series include:

- Capable of 10Gbps transmission at 500MHz, fulfilling Cat.6A standards for robust network performance.
- Designed with EMI prevention to maintain signal integrity in noisy electrical environments.
- Features a user-friendly design for quick and straight forward assembly, reducing installation time.
- Compatible with ix Industrial cable assemblies, enhancing versatility for industrial applications.

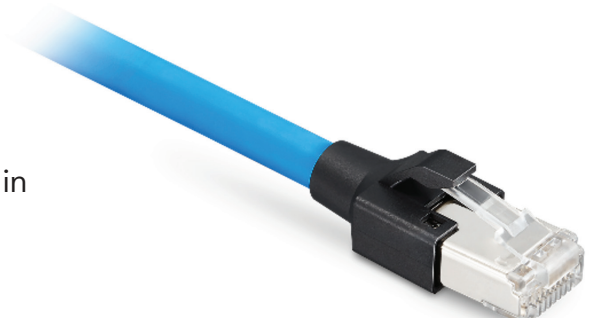

Dimensions

TM61P-88P

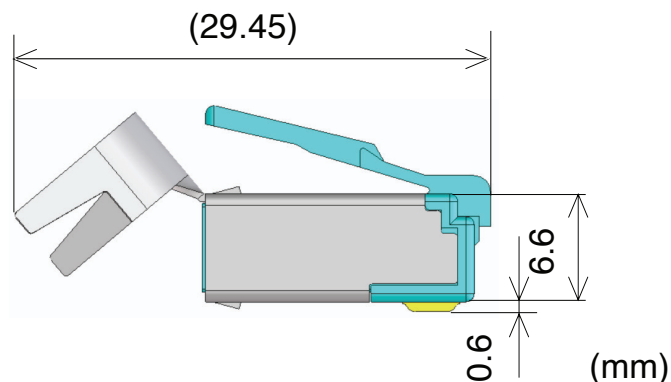
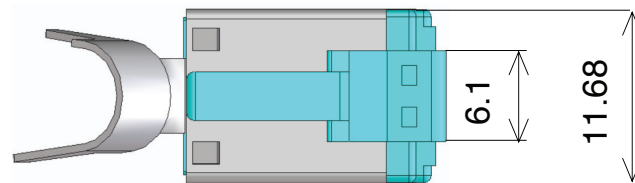
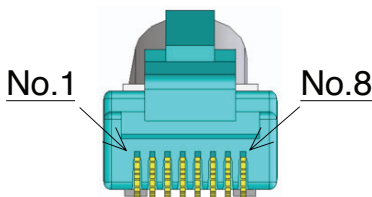

[CLICK HERE FOR MORE INFORMATION](#)

[CLICK HERE TO ORDER SAMPLE NUMBER: US-TM61PPSAMPLE-24](#)

Extensive Lineup of Interface Connectors for Industrial Ethernet

The rise of Industry 4.0, the trend of automation and data exchange in manufacturing technologies, has led to greater efficiency as manufacturing sites use ICT (Information & Communications Technology) at increased rates. As a result, connector needs have also diversified.

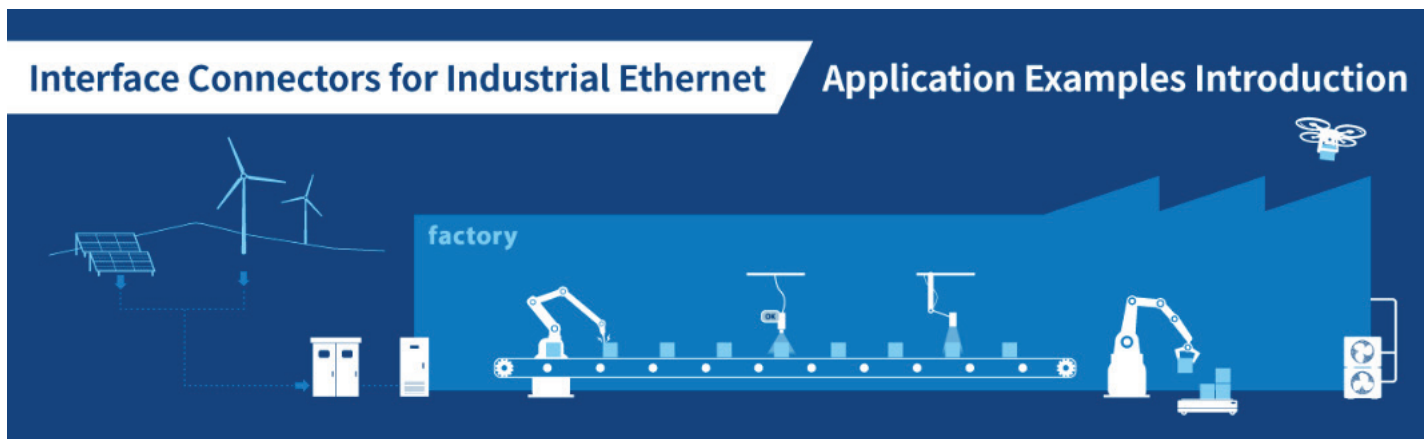

Select Based on Transmission Standards

Ethernet standards vary depending on the transmission speed and cables used. Hirose offers a wide range of connectors compatible with cables supporting various transmission standards, from Cat.5e, a common 1Gbps LAN cable, to Cat.6A for next-generation Ethernet.

Series Name	ix Industrial™	TM61P	TM31P	TM21P	TM21R	LF	T1 (Under Development)
Features	IEC 61076-3-124	IEC60603-7 Cat.6A RJ-45 Plug	IEC60603-7 Cat.6A RJ-45 Plug	IEC60603-7 Cat.5e RJ-45 Plug	IEC60603-7 Cat.5e RJ-45 Receptacle	Shielded Round Waterproof	IEC 63171-6 Single Pair Ethernet
Cat.5e	✓	✓	✓	✓	✓	✓*	-
Cat.6	✓	✓	✓	-	-	-	-
Cat.6A	✓	✓	✓	-	-	-	-

*Supports transmission speeds equivalent to Cat.5e.

Cat.6A Compatible Modular Plug /Variation

Applicable Cable	TM61P Series	TM31P Series
Conductor	24-26 AWG Stranded Cable	24-27 AWG Stranded Cable
Insulation Diameter	ø0.9-1.0mm	ø0.9-1.0mm
Sheath Outer Diameter	ø6.0-6.5mm	ø5.8-6.0mm
Other	Available Latch Covers: - Black only - Short latch cover	Available Latch Covers: - Multiple colors - Protective latch cover - Short latch cover

Specifications

Rated Current	1A
Rated Voltage	125V AC
Operating Temperature	-25 to +60°C*
Contact Resistance	50mΩ Max.
Withstanding Voltage	500V AC for 1 min.
Insulation Resistance	100MΩ Min. (100V DC)
Mating Durability	200 times

- RoHS Compatible



For additional information please go to www.hirose.com/product/series/TM61P

Specifications herein are subject to change without notice. Contact Hirose for latest specifications, drawings, or availabilities.

STAY CONNECTED

